

Titanium Membrane Solutions

If we can pump it - We can filter it!

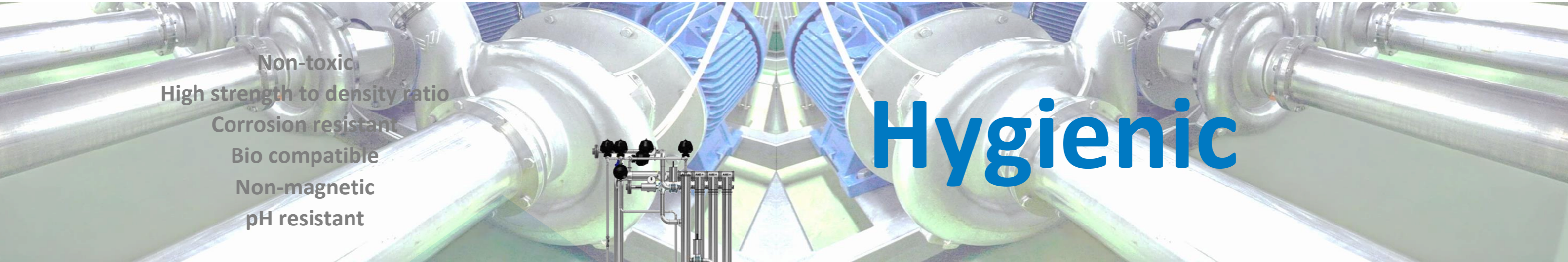

- Non-toxic
- High strength to density ratio
- Corrosion resistant
- Bio compatible
- Non-magnetic
- pH resistant

The world's first and only Titanium (Ti) metal filtration system, its ability to filter high solids, high/low temperature, high/low Ph, fats, oils, grease and generally all the materials every other filter fails with.

The Ti membrane goes well beyond just filtering difficult media, it also concentrates solids to slurries.

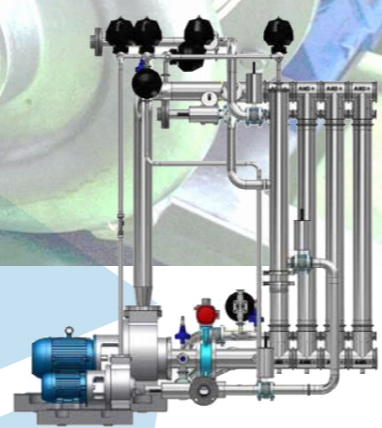

Benefits of



- Grease & Oil Reduction
- Chemicals
- Micro Filtration
- Separation
- 99% Fats Reduction
- 99%+ COD & BOD Reduction
- Lower Energy
- Ultra-Filtration
- 99% Less Suspended Solids
- Very High Solids
- Extended Membrane Warranty*

Pharmaceutical
Food
Beverage
Dairy
Alcohol
Laboratory



Centrifugal



CIP Pumps



Twin Screw



Static Mixers



Hygienic

Hydro Conveying



Unloaders



Air Operated Double Diaphragm



Progressive Cavity



Flow Meters



Piston Pumps



Positive Displacement Lobe

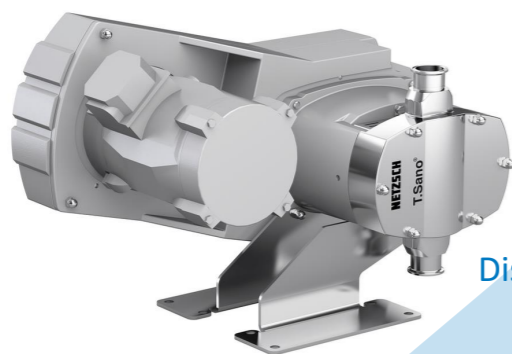

Dynamic Mixers



Dosing



Water Pump Sets

